



INTRODUCTION

CONSTRUCTION :

Brake Motors are used for various applications, where instantaneous stopping of the driven load is required. The operation of the brake is "FAIL SAFE TYPE" i.e. normally ON. When the electrical power to the motor is cut-off or the power fails, the brake is applied.

Brake Motor is a combination of an A.C. induction motor and an electromagnetic AC or DC brake. The electromagnetic brake is mounted on the non-driving end of the motor.

DC brake motors are provided with a rectifier which provides the required DC voltage to the brake coil which in turn operates the brake. the supply to the rectifier is fed from any two terminals (between any two phases) in the main terminal box of the motor.

General applications of the Brake motors are printing machinery, textile machinery, rolling mills, cranes, Hoists, material handling equipments, machine tools etc.

WORKING :

when the power to the motor is switched off, a braking torque is generated which presses the armature plate of the brake against the mounting flange. When the supply resumes, a magnetic field is produced in the brake coil and this pulls the armature plate against the spring force and the shaft is now free to rotate.

RANGE OF HINDUSTAN BRAND BRAKE MOTORS :

Kw	: 0.093 to 15.0 KW
RPM	: 3000,1500,1000,750.
Mounting	: foot (B3), flange(B5)
	: face (B14)& combinations
Frame	: 63 to 160 L
Voltage	: 415 Volts /as required
Frequency	: 50 Hz.
Braking torque	: up to 250 Nm
Brake coil voltage	: 190 v Dc (Other voltages on request)
Degree of protection	: IP54
Duty cycle	: S1-S8.

SPECIAL FEATURES :

- Brake motors are simple & rugged. So easy for maintenance.
- No separate DC supply is required as the rectifier is provided which gives the required DC voltage for energisation of the brake.
- The rectifier is mounted inside the main terminal box so no separate terminal box is required.

GENERAL GUIDELINES FOR THE SELECTION OF SUITABLE BRAKE MODEL :

The brakes are rated by torque & selection of suitable model can be made by calculating the required torque, rating of the brake & then matching it with static torque.

Torque(Nm)= 9550x(KW/RPM)xSAFETY FACTOR(sf)-where Kw-- Kilowatts of motor.
RPM-- Speed of motor

SF--Safety factor depending upon type of prime mover & load.

For Electric motor-- SF=2 to 3

For diesel engine-- SF=4 to 5

For compressor- SF=5 to 6.

BRAKE COIL CONNECTION DIAGRAM :

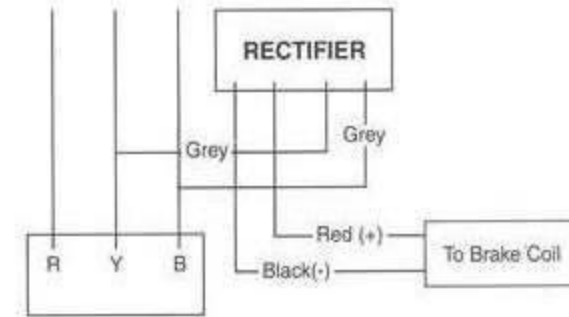

Brake coil is energized by DC side switching as shown in the diagram.

APPLICATIONS

Hindustan Brake Motors can be used in many applications, such as

- Machine Tools
- Textile Machinery
- Cranes & Hoists
- Printing Machinery
- Geared Motors
- Cable Reeling Drums
- Rolling Mills

ENQUIRY DETAILS

When placing an enquiry, please furnish the following details.

- Application details
- Motor power & speed
- Brake size/ required braking torque.
- Mounting
- No. of start/ stops per hour
- Duty cycle

MECHANICAL DIMENSIONS

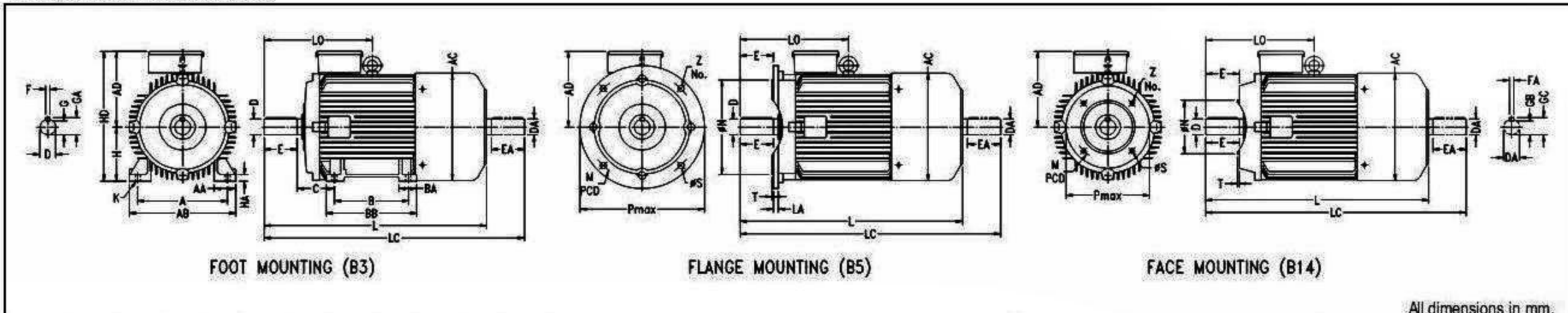

All dimensions in mm.

Frame Size	Brake Size	L	LC	LO	AC	AD	D, DA	E, EA	F, FA	GA, GC	G, GB	For foot mounted motors (B3)								For flange mounted motors (B5)						For face mounted motors (B14)									
												A	B	C	H	K	AA	AB	BB	BA	HA	HD	P max	M PCD	øN	øS	Z No.	T	LA	P max	M PCD	øN	øS	Z No.	T
63	6	270	300	-	124	100	11	23	4	12.5	8.5	100	80	40	63	7	27	122	102	27	7	163	140	115	95	10	4	3	9	90	75	60	M5	4	2.5
71	6	310	346	-	140	105	14	30	5	16	11	112	90	45	71	7	31	134	112	31	8	176	160	130	110	10	4	3.5	9	105	85	70	M6	4	2.5
	8																																		
80	8	355	402	-	158	122	19	40	6	21.5	15.5	125	100	50	80	10	32	150	125	32	9	202	200	165	130	12	4	3.5	10	120	100	80	M6	4	3
	10	365	412																																
90S	12	415	472	-	180	129	24	50	8	27	20	140	100	56	90	10	33	168	124	32	10	219	200	165	130	12	4	3.5	10	140	115	95	M8	4	3
90L	12	440	497																																
100L	14	475	542	-	198	152	28	60	8	31	24	160	140	63	100	12	43	200	180	46	14	252	250	215	180	15	4	4	11	160	130	110	M8	4	3.5
112M	14	495	562																																
132S	18	580	667	257	262	185	38	80	10	41	33	216	140	89	132	12	52	256	180	48	16	317	300	265	230	15	4	4	12	200	165	130	M12	4	3.5
132M	18	618	705	260																															
160M	18	715	832	354	311	211	42	110	12	45	37	254	210	108	160	15	64	304	260	60	20	371	350	300	250	19	4	5	13	-	-	-	-	-	-
160L	18	759	876																																
180M	20	776	894	381	354	233	48	110	14	51.5	42.5	279	241	121	180	15	65	335	297	101	24	413	350	300	250	19	4	5	13	-	-	-	-	-	-
	180L	25	833																																
200L	25	892	1012	416	395	276	55	110	16	59	49	318	305	133	200	19	84	386	365	74	26	476	400	350	300	19	4	5	15	-	-	-	-	-	-