



**M/S Union Engineering Co.**

16, Pankaj 'A', LBS Marg, Opp. Indradeep Society,  
Ghatkopar - West. Mumbai - 400 086.

Ph : +91 - 22 - 25133850. Fax : +91 - 22 - 25133850.

Email : unionengg@gmail.com, union\_engg@yahoo.co.in.

Website : www.unionengg.in

**FLAME PROOF MECHANICAL DIMENSIONS**



**DIMENSIONS OF FOOT MOUNTED FLAME PROOF MOTORS (B3)**

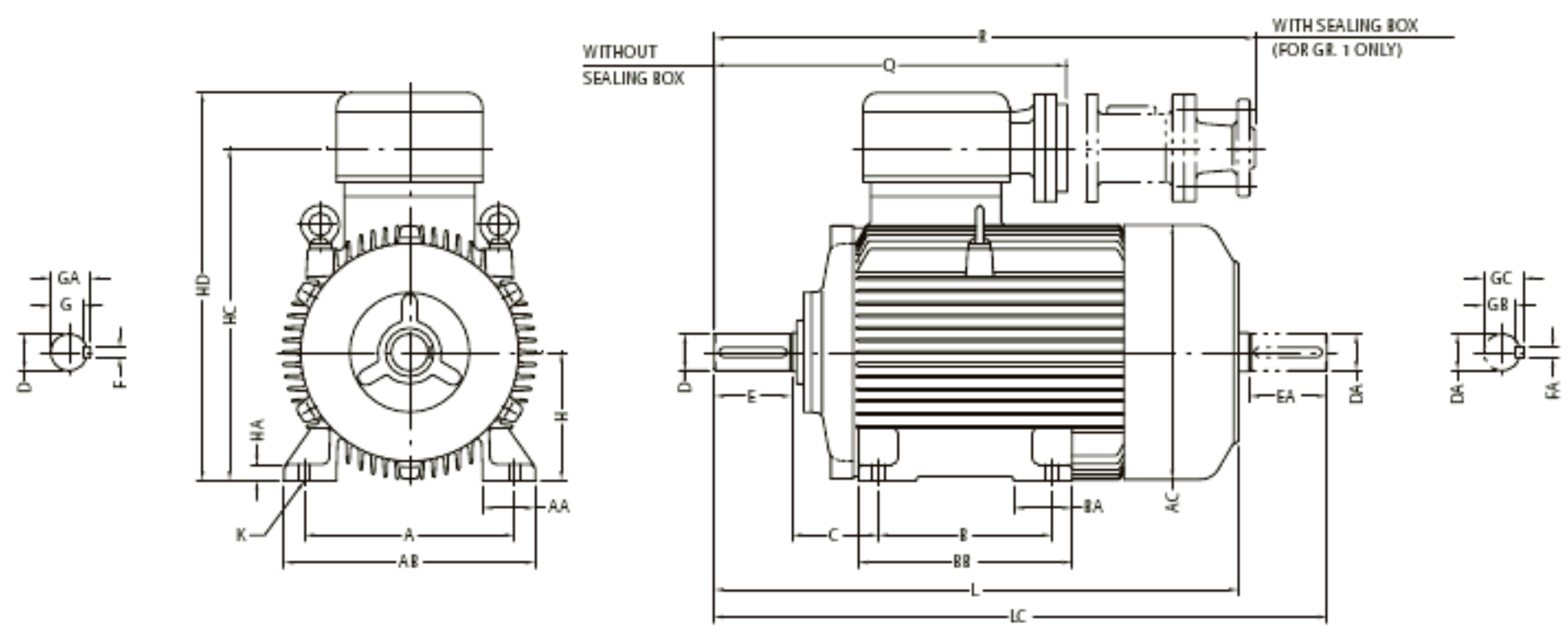

Frame Size	A	B	C	H	K	L	LC	AA	AB	BB	BA	AC	HA	HC	HD	Q	R	D, DA	E, EA	F, FA	GA, GC	G, GB
63 FLP	100	80	40	63	7	242	270	30	128	102	32	124	9	188	225	210	310	11	23	4	12.5	8.5
71 FLP	112	90	45	71	7	284	319	35	140	112	35	140	10	205	247	225	322	14	30	5	16	11
80 FLP	125	100	50	80	10	305	355	38	156	130	40	162	12	225	265	245	342	19	40	6	21.5	15.5
90 FLP	140	125	56	90	10	375	435	40	180	155	48	182	12	260	316	305	460	24	50	8	27	20
100L FLP	160	140	63	100	12	417	482	45	200	170	50	198	14	277	334	325	480	28	60	8	31	24
112M FLP	190	140	70	112	12	438	505	53	226	180	55	226	15	302	358	325	480	28	60	8	31	24
132M FLP	216	178	89	132	12	540	630	64	258	220	60	266	17	342	400	365	520	38	80	10	41	33
160L FLP	254	254	108	160	15	666	786	72	320	306	78	330	25	400	460	454	630	42	110	12	45	37
180L FLP	279	279	121	180	15	765	885	80	355	340	95	360	25	450	515	500	680	48	110	14	51.5	42.5
200L FLP	318	305	133	200	19	820	940	82	398	370	95	400	28	495	565	535	695	55	110	16	59	49
225S FLP	356	286	149	225	19	886	1006	97	440	379	123	440	30	544	615	532	692	55	110	16	59	49
225M FLP		311																				
225SX FLP		286																				
225MX FLP		311																				
250M FLP	406	349	168	250	24	1010	1160	109	496	439	120	484	33	594	665	569	729	60	140	18	64	53
250MX FLP																		65			69	58
280S FLP	457	368	190	280	24	1130	1280	120	557	519	170	543	40	700	797	689	-	65	140	18	69	58
280M FLP		419																				
280SX FLP		368																				
280MX FLP		419																				
																		75		20	80	68

Suffix "X" denotes motors other than 2 pole motors.

**Authorised Dealers & Stockist :**

Estd. Since 1974.



# M/S Union Engineering Co.

16, Pankaj 'A', LBS Marg, Opp. Indradeep Society,  
Ghatkopar - West. Mumbai - 400 086.

Ph : +91 - 22 - 25133850. Fax : +91 - 22 - 25133850.

Email : unionengg@gmail.com, union\_engg@yahoo.co.in.

Website : www.unionengg.in

## FLAME PROOF MECHANICAL DIMENSIONS



**DIMENSIONS OF FLANGE MOUNTED FLAME PROOF MOTORS (B5)**

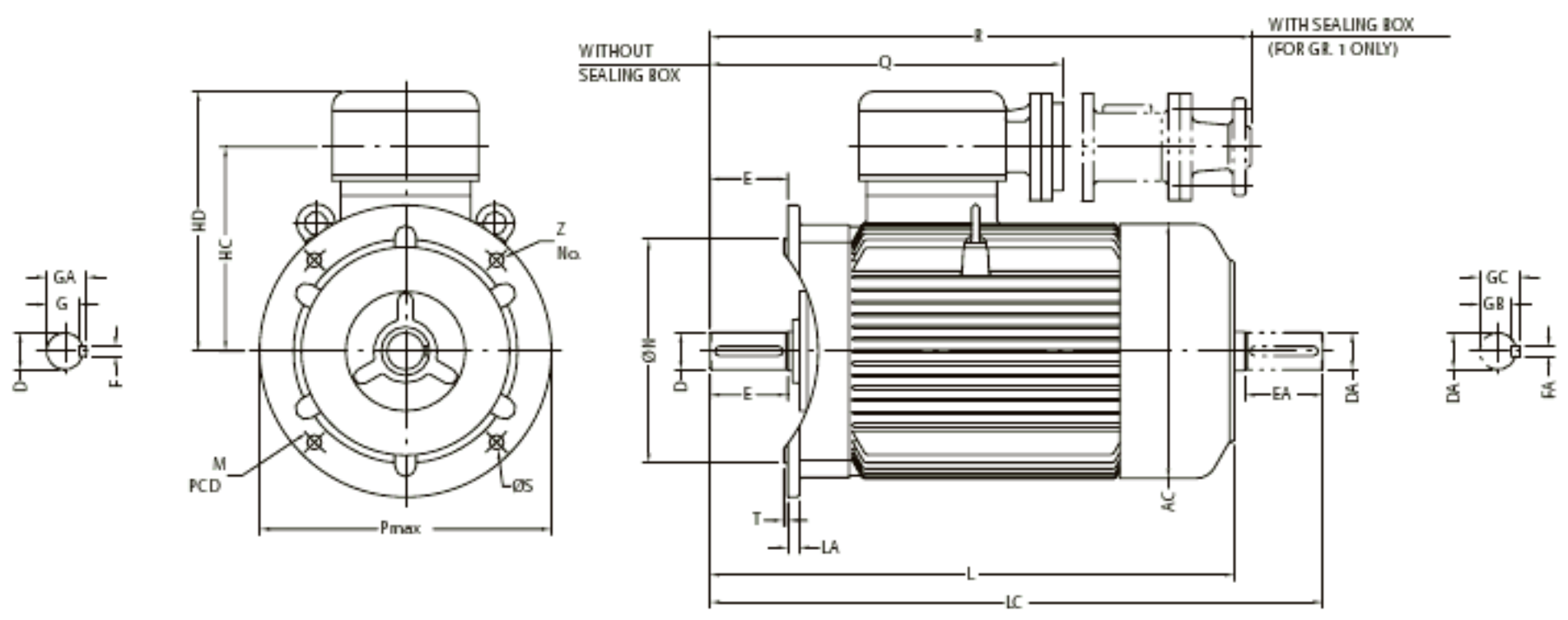

Frame Size	L	LC	AC	HC	HD	Q	R	D, DA	E, EA	F, FA	GA, GC	G, GB	P <sub>max</sub>	M PCD	oII	oS	Z No.	T <sub>max</sub>	LA
63 FLP	242	270	124	125	162	210	310	11	23	4	12.5	8.5	140	115	95	10	4	3	9
71 FLP	284	319	140	134	176	225	322	14	30	5	16	11	160	130	110	10	4	3.5	9
80 FLP	305	355	162	145	185	245	342	19	40	6	21.5	15.5	200	165	130	12	4	3.5	10
90 FLP	375	435	182	170	226	305	460	24	50	8	27	20	200	165	130	12	4	3.5	10
100L FLP	417	482	198	177	234	325	480	28	60	8	31	24	250	215	180	15	4	4	11
112M FLP	438	505	226	190	246	325	480	28	60	8	31	24	250	215	180	15	4	4	11
132M FLP	540	630	266	210	268	365	520	38	80	10	41	33	300	265	230	15	4	4	12
160L FLP	666	786	330	240	300	454	630	42	110	12	45	37	350	300	250	19	4	5	13
180L FLP	765	885	360	270	335	500	680	48	110	14	51.5	42.5	350	300	250	19	4	5	13
200L FLP	820	940	400	295	365	535	695	55	110	16	59	49	400	350	300	19	4	5	15
225S FLP	886	1006	440	544	615	532	692	55	110	16	59	49	450	400	350	19	8	5	16
225M FLP						562	722												
225SX FLP	916	1066	440	544	615	562	722	60	140	18	64	53	450	400	350	19	8	5	16
225MX FLP						562	722												
250M FLP	1010	1160	484	594	665	569	729	60	140	18	64	53	550	500	450	24	8	5	18
250MX FLP								65			69	58							
280S FLP	1130	1280	543	420	517	689	-	65	140	18	69	58	550	500	450	24	8	5	18
280M FLP								65			69	58							
280SX FLP								65			69	58							
280MX FLP								75			20	80							

Suffix "X" denotes motors other than 2 pole motors.



# M/S Union Engineering Co.

16, Pankaj 'A', LBS Marg, Opp. Indradeep Society,  
Ghatkopar - West. Mumbai - 400 086.

Ph : +91 - 22 - 25133850. Fax : +91 - 22 - 25133850.  
Email : unionengg@gmail.com, union\_engg@yahoo.co.in.  
Website : www.unionengg.in



## FLAME PROOF MECHANICAL DIMENSIONS

### DIMENSIONS OF FACE MOUNTED FLAME PROOF MOTORS (B14)

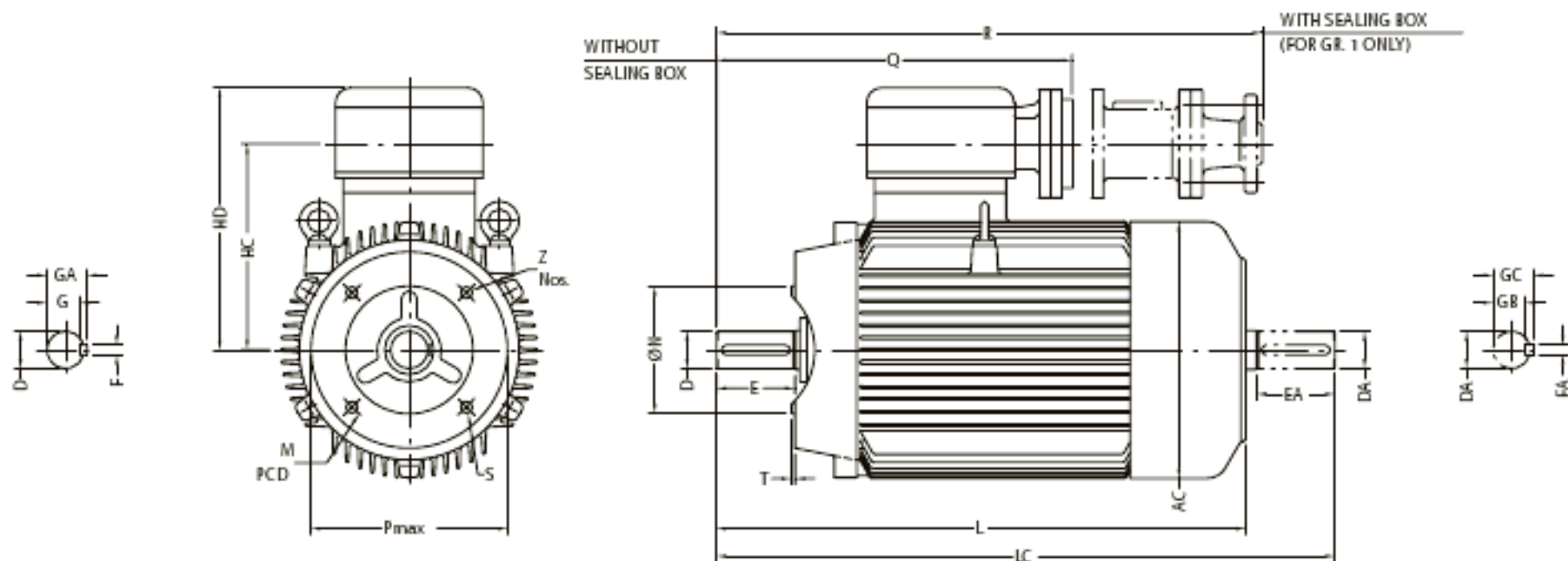

Frame Size	L	LC	AC	HC	HD	Q	R	D, DA	E, EA	F, FA	GA, GC	G, GB	P <sub>max</sub>	M PCD	α	S	Z fl.o.	T
63 FLP	242	270	124	125	162	210	310	11	23	4	12.5	8.5	90	75	60	M5	4	2.5
71 FLP	284	319	140	134	176	225	322	14	30	5	16	11	105	85	70	M6	4	2.5
80 FLP	305	355	162	145	185	245	342	19	40	6	21.5	15.5	120	100	80	M6	4	3.0
90 FLP	375	435	182	170	226	305	460	24	50	8	27	20	140	115	95	M8	4	3.0
100L FLP	417	482	198	177	234	325	480	28	60	8	31	24	160	130	110	M8	4	3.5
112M FLP	438	505	226	190	246	325	480	28	60	8	31	24	160	130	110	M8	4	3.5
132M FLP	540	630	266	210	268	365	520	38	80	10	41	33	200	165	130	M12	4	3.5