



M/S Union Engineering Co.

16, Pankaj 'A', LBS Marg, Opp. Indradeep Society,
Ghatkopar - West. Mumbai - 400 086.

Ph : +91 - 22 - 25133850. Fax : +91 - 22 - 25133850.

Email : unionengg@gmail.com, union_engg@yahoo.co.in.

Website : www.unionengg.in

STANDARD MOTORS – MECHANICAL DIMENSIONS



DIMENSIONS OF FOOT (B3) & FLANGE (B5) MOUNTED STANDARD MOTORS

FOOT MOUNTING (B3)

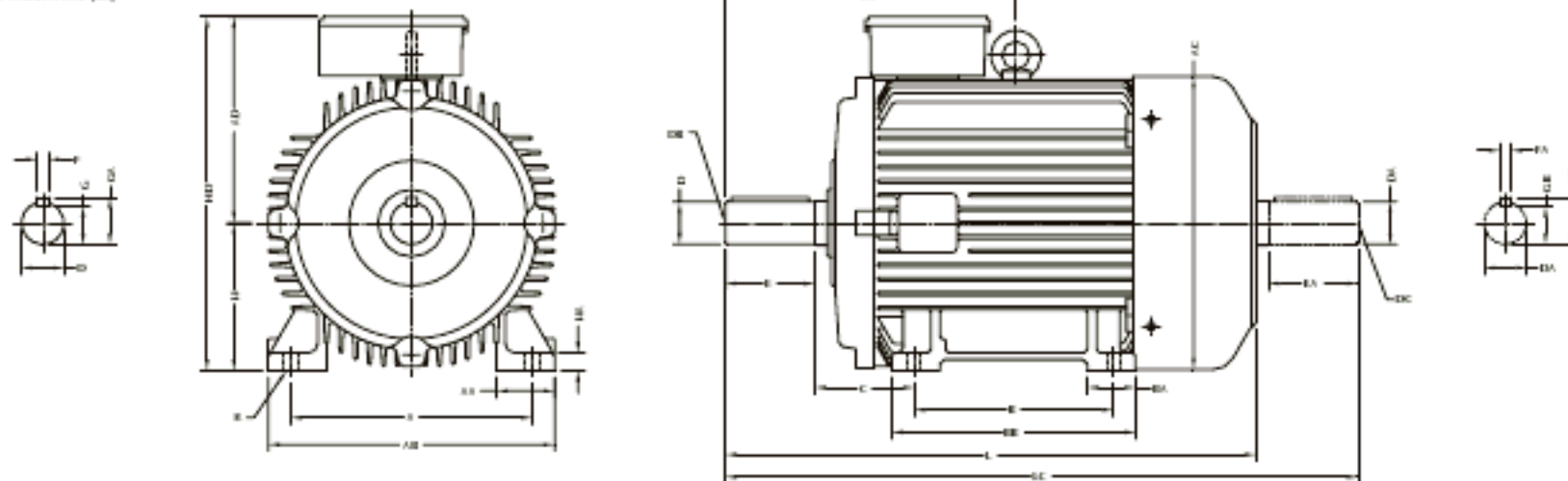

FLANGE MOUNTING (B5)

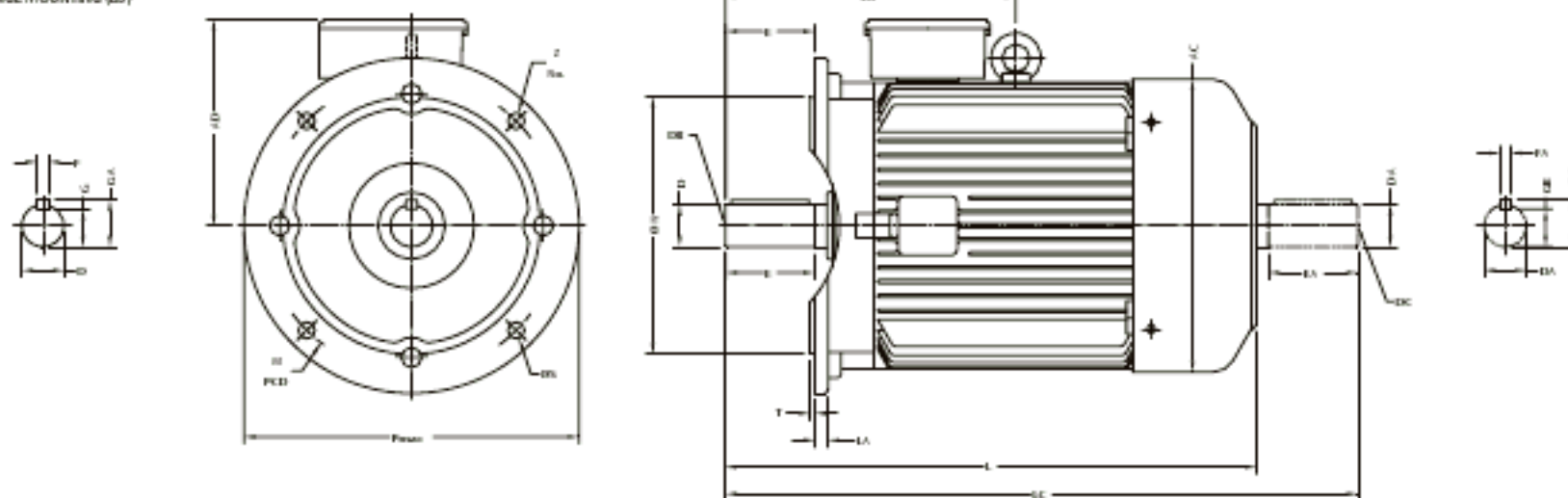

DIMENSIONS OF FACE MOUNTED STANDARD MOTORS (B14)

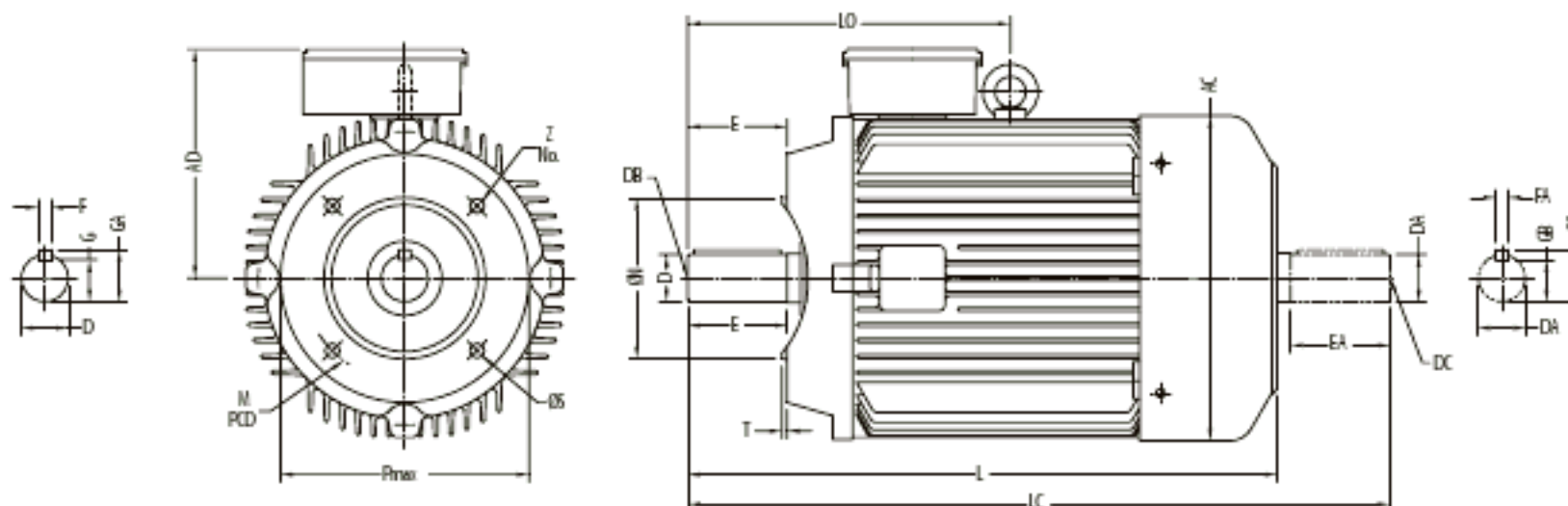

Frame Size	L	LC	LO	AC	AD	P _{max}	M PCD	øH	øS	Z No.	T	D, DA	DB, DC	E, EA	F, FA	GA, GC	G, GB
56	180	204	-	110	80	80	65	50	M5	4	2.5	9	M4	20	3	10.2	7.2
63	206	236	-	124	100	90	75	60	M5	4	2.5	11		23	4	12.5	8.5
71	240	276	-	140	105	105	85	70	M6	4	2.5	14	M5	30	5	16	11
80	277	324	-	158	122	120	100	80	M6	4	3	19	M6	40	6	22	16
90S	297	354	-	180	129	140	115	95	M8	4	3	24	M8	50	8	27	20
90L	322	379															
100L	366	433	-	198	152	160	130	110	M8	4	3.5	28	M10	60	8	31	24
112M	389	456	230	222	165	160	130	110	M8	4	3.5	28		60	8	31	24
132S	437	524	257	262	185	200	165	130	M12	4	3.5	38	M12	80	10	41	33
132M	475	562	260														